

Technical Information

MOBICONE MCO 110(i) PRO



Track-mounted cone crusher

For use in natural stone

MOBICONE PRO

Series

HIGHLIGHTS

- > Extremely robust design
- > Very high production output with low-maintenance operation
- > E-DRIVE diesel-electric drive concept with the option to connect an external power supply
- > Ideal for combination with the upstream MOBICAT MC 120(i) PRO jaw crusher



MOBICONE MCO 110(i) PRO mobile cone crusher

The MOBICONE MCO 110(i) PRO mobile cone crusher stands out with its extremely robust design and very high performance.

As an option, the plant can be operated using an external power source and it requires impressively little maintenance.

TECHNICAL DATA MCO 110(i) PRO

Feeding unit	
Feed capacity up to approx. (t/h)	470
Max. feed size (mm)	240
Feed height approx. (mm)	2,600
Hopper volume (m ³)	7.5
Feed opening width x length (mm)	1,820 x 3,700
Feed height with filling aid for rearward feeding approx. (mm)	2,900
Hopper volume with filling aid for rear feeding (m ³)	9.2
Feed opening width with filling aid for rear feeding approx. (mm)	4,250
Feeding conveyor	
Width x length (mm)	1,200 x 7,500
Speed	variable (controlled by CFS)
Crusher	
Cone crusher type	KX 350
Crusher system size d= (mm)	1,120
Crusher weight approx. (kg)	16,200
Crusher drive type, approx. (kW)	electric, 250

Crusher	
Crushing capacity for secondary end product 0/45 up to approx. (t/h)	390 ¹⁾
Crushing capacity for secondary end product 0/56 up to approx. (t/h)	420 ¹⁾
Crushing capacity for tertiary end product 0/22 up to approx. (t/h)	230 ¹⁾
Crusher discharge conveyor	
Width x length (extended) (mm)	1,000 x 9,200 (10,700)
Discharge height approx. (extended) (mm)	3,600 (4,400)
Power supply unit	
Drive concept	diesel-electric
Scania diesel engine drive power (kW)	368 - 410 (1,800 rpm) ²⁾
Generator (kVA)	500
Transport position dimensions	
Height approx. (mm)	3,850
Length approx. (mm)	17,730
Width approx. (mm)	3,000
Transport weight basic plant - max. equipment approx. (kg)	49,500 - 58,000

¹⁾ Depending on the type and composition of the feed material, as well as the feed size and the desired final grain size, incl. 10 - 15 % oversize grain

²⁾ Depending on the respective exhaust emission standard

OPERATING POSITION

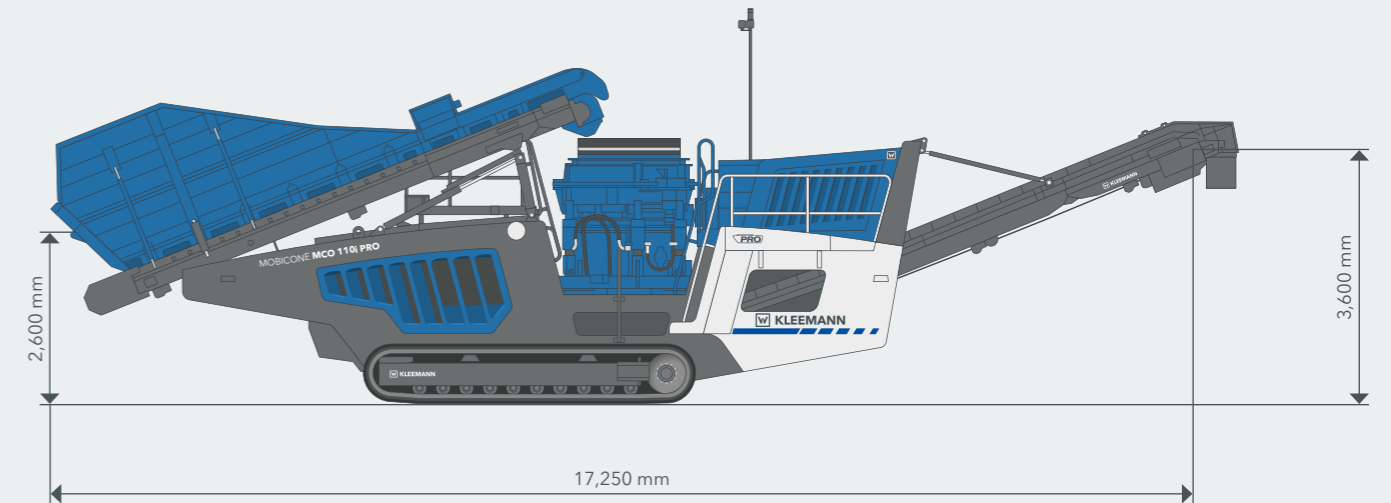

MATERIAL FLOW

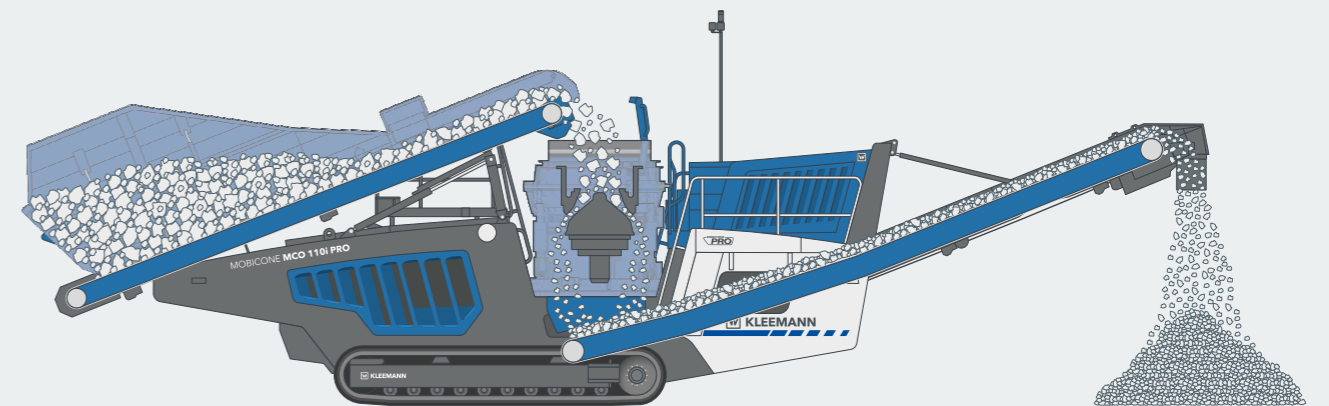

The MOBICONE MCO 110(i) PRO is equipped with a simple sliding mechanism on the feed unit, which puts the machine into a compact transport position and enables quick set-up. The sliding mechanism also makes it easy to adjust the material discharge pattern into the crusher - for optimal loading. Fitted with the „Tramp

Release“ and „Ring Bounce Detection“ intelligent overload systems, safety and stable processes can be guaranteed even under difficult conditions.

Easy operation is ensured by the intuitive SPECTIVE and SPECTIVE CONNECT operating concept.

STANDARD EQUIPMENT

- > Hopper made of KRS (KLEEMANN Resistant Steel), hopper volume approx. 7.5 m³
- > Frequency-controlled feeding conveyor, automatic control depending on crusher level thanks to continuous crusher feed via the Continuous Feed System (CFS)
- > Metal detector under the feeding conveyor protects the cone crusher against uncrushable metallic material
- > Overload system in crusher enables opening of the crushing chamber if unbreakable material enters
- > Intelligent overload detection ("Ring Bounce Detection") protects the crusher against damage; two modes available
- > Wear indicator records the current wear level on the crushing tool
- > Automatic lubrication of crusher bearing
- > SPECTIVE control concept: menu-guided user interface, 12-inch control panel; WITOS FleetView telematics system for efficient fleet and service management
- > Remote control: wired and radio remote control incl. switch-off function for feeding unit
- > Water spray system for dust reduction
- > Lighting

OPTIONS

- > SPECTIVE CONNECT displays all important machine information directly on the smartphone
- > Replaceable hopper elements: KRS Kleemann Resistant Steel and rubber wear lining
- > Hopper filling aids for rear feeding: width of feed opening 4,400 mm; hopper volume approx. 9.2 m³
- > Magnetic remover for lifting out magnetic elements
- > Extended crusher discharge conveyor, can be folded hydraulically
- > Belt scale in crusher discharge conveyor, can be read via SPECTIVE
- > Crusher discharge conveyor belt cover (standard and extended)
- > Head scraper on crusher discharge conveyor
- > External power supply for more economical mains operation
- > Line coupling for interlinking with other KLEEMANN plants
- > Camera system monitors the feeding unit and the crusher from the ground, available with additional radio extension
- > Oversize grain returning for returning oversize grain material from a screening plant, can be fitted on left or right
- > 16 A/32 A power supply for supplying service tools
- > Water pump with pressure monitoring
- > Raised engine air intake for lower dust load
- > Diesel refuelling pump: hose system incl. pump, refuelling from a separate tank possible
- > Track pads for crawler tracks to protect the ground
- > Premium lighting for expanded illumination of work areas
- > Climate package: Heating and cooling package (self-sufficient parked heating)



For the machine to operate efficiently, it is essential that the correct wear parts are used. KLEEMANN original parts are optimally adapted to the requirements of both the user and the machine. We use our application know-how and expert advice to help our customers find the right wear part to meet their specific needs. For further information, visit: parts.wirtgen-group.com

KLEEMANN GmbH

Manfred-Wörner-Str. 160
73037 Göppingen
Germany

T: +49 7161 206-0
F: +49 7161 206-100
M: info@kleemann.info

www.kleemann.info

