



Mobile jaw crusher

MOBICAT MC 100i EVO



A LONG HERITAGE OF EXPERTISE

Efficient crushing and screening plants.

For the past 100 years, KLEEMANN GmbH has been developing and manufacturing machines and plants for the natural stone and recycling industries.

High levels of performance and innovative details, simple handling and maximum safety for the operator - this is what KLEEMANN crushing and screening plants stand for.



THE KLEEMANN PRODUCT RANGE

MOBICAT
Mobile jaw crushers

MOBIREX
Mobile impact crushers

MOBICONE
Mobile cone crushers

MOBISCREEN
Mobile screening plants

MOBIBELT
Mobile stackers

Over 100 years of
tradition

A WIRTGEN GROUP Company
An internationally active group of companies



With more than 200
subsidiaries and dealers in Germany and abroad

KLEEMANN

HIGHLIGHT OVERVIEW

Perfectly equipped.



- > Simple transport
- > Fast set-up

01 Feeding unit

- > Feeding unit with integrated hopper walls

02 Prescreening

- > Coarse prescreening thanks to vibrating feeder

03 CFS (Continuous Feed System)

- > Continuous crusher feed via the CFS (Continuous Feed System)

04 Crusher unit

- > Powerful jaw crusher

05 Drive

- > Efficient and powerful diesel-direct drive

06 Control system concept

- > Easy-to-operate control system

07 Magnet and crusher discharge conveyor

- > Optimized conveyor unit



WELL THOUGHT-OUT FEEDING UNIT

With integrated prescreening.

up to 243 US t/h
Feed capacity

approx. 4.2 yd³
Hopper volume

approx. 9.3 yd³
Hopper volume with large hopper extension



Feeding unit with integrated hopper walls - for a fast set-up.

To ensure quick set-up and simple transport, the machines in the MOBICAT MC 100i EVO line are equipped with integrated hopper walls. An optional hopper extension is available for loading by means of a wheel loader. It can be folded and locked hydraulically and can also be secured mechanically. Comfortable and safe operation takes place entirely from the ground. Furthermore, an optional small hopper extension is available for permanent installation on the plant - allowing a total hopper volume of 7.8 yd³.

Discharge of fines in advance

The MC 100i EVO has a long vibrating feeder with an integrated slotted grate or punched plate. Fine material is thus coarsely separated from the feed material and does not have to run

through the crusher. Rather, it is discharged by the optional side discharge conveyor. This guarantees better results and less wear.

Side discharge conveyor

The side discharge conveyor is available in two versions, can be installed on both sides and can remain on the machine for transport. Discharge heights of up to 6' 11" or 9' 10" are possible. The belts are provided with a spray system to reduce the dust load.

KLEEMANN > PROCESS KNOWLEDGE

Optimized output capacity - thanks to well prepared feed material

The composition of the feed material and the feed size significantly influence the output capacity. To guarantee trouble-free and low-wear operation, the feed material should be prepared as well as possible.

- > Take note of the size and edge length of the material
- > Select the feed size to match the final grain size and max. permissible crushing ratio
- > Sort out any uncrushable material, e.g. steel beams, cables, wood, films/foils
- > Ensure uniform loading of the plant - an overfilled feed hopper and a continuously empty feed hopper can lead to increased wear

CONTINUOUS FEED SYSTEM (CFS)

Higher efficiency thanks to uniform loading.

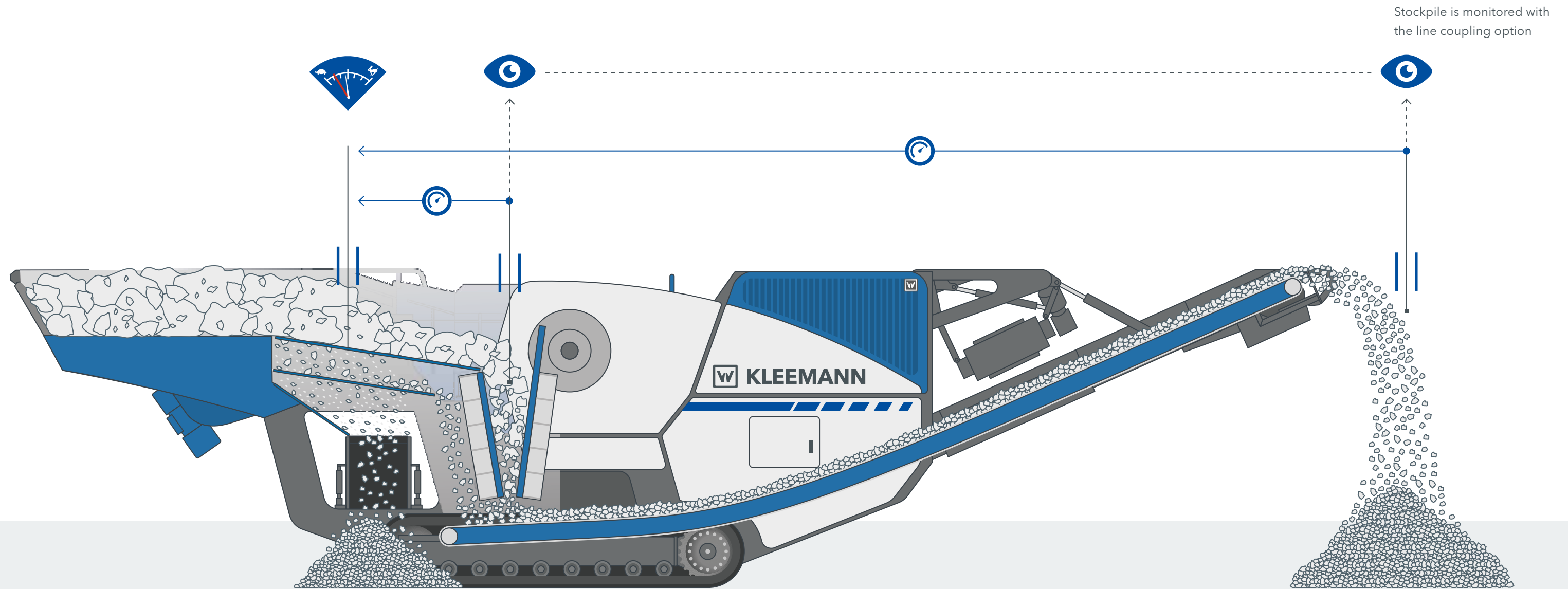

Uniform loading is indispensable for a good product, optimum throughput and low wear.

To ensure that the crushing chamber is always uniformly filled, the optional Continuous Feed System (CFS) monitors the crusher level with an ultrasonic probe and, with the line coupling option, the height of the stockpile. The CFS independently regulates the frequency of the vibrating feeder and prescreen. A backlog

is therefore avoided and crusher utilization is optimized. The CFS facilitates the operator's work as the machine automatically regulates a homogeneous material flow, thus ensuring optimum loading of the crusher.

KLEEMANN > PROCESS KNOWLEDGE

The CFS controls the vibrating chute speed so that the material on the chute does not pile up too high. Fine content can thus be screened out before it runs through the crusher.

Result: The crusher now only has to deal with the material that really needs to be crushed!

POWERFUL CRUSHER UNIT

The heart of the machine.

Powerful crusher unit for high crushing capacity and throughput.

The MC 100(i) EVO's crusher unit is the centrepiece of the machine. Its extra-long articulated crusher jaw guarantees optimal

material intake. Innovative functions such as the load reduction system or the simple gap setting offer real added value.

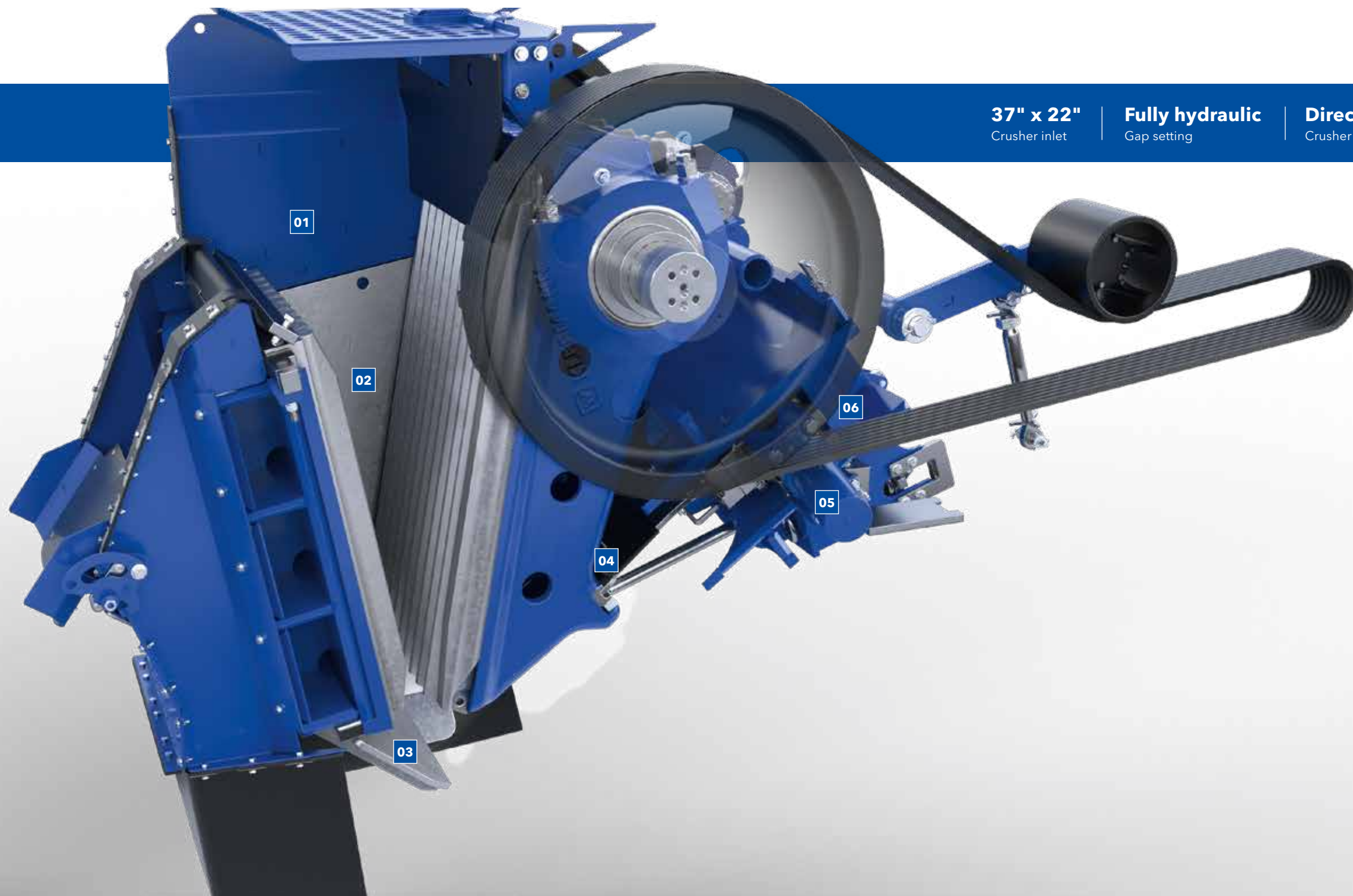

37" x 22"
Crusher inlet

Fully hydraulic
Gap setting

Direct
Crusher drive (via fluid coupling)

- 01** Optimized crusher geometry with long crusher jaw
- 02** Crusher jaws with Regular Teeth, Sharp Teeth
- 03** Gentle material transfer thanks to deflector plate
- 04** Mechanical overload protection thanks to pressure plate
- 05** Crusher unblocking system (optional)
- 06** Convenient gap setting via push button on the touch panel

01 Crusher geometry

The crusher geometry features an optimum design. Flattened transfer from the prescreen or vibrating feeder to the crushing chamber means the material can tilt into the crushing chamber without any restrictions. When the articulated crusher jaw is pulled up, the material cannot pile up and fewer blockages are created.

The deflector plate at the crusher outlet guarantees gentle material transfer onto the crusher discharge conveyor. The large material tunnel prevents blockades and is easily accessible from the side.

Result: High throughput combined with high reliability.

02 Gap setting

The gap setting is made conveniently and safely at the touch display. Adjustment is made fully hydraulically by means of a wedge system.

Rule of thumb: The closed side setting is calculated from final grain size = 1.6 x CSS. With a desired final grain size of 0 - 4.7, the optimum CSS would therefore be 2.9 inch.

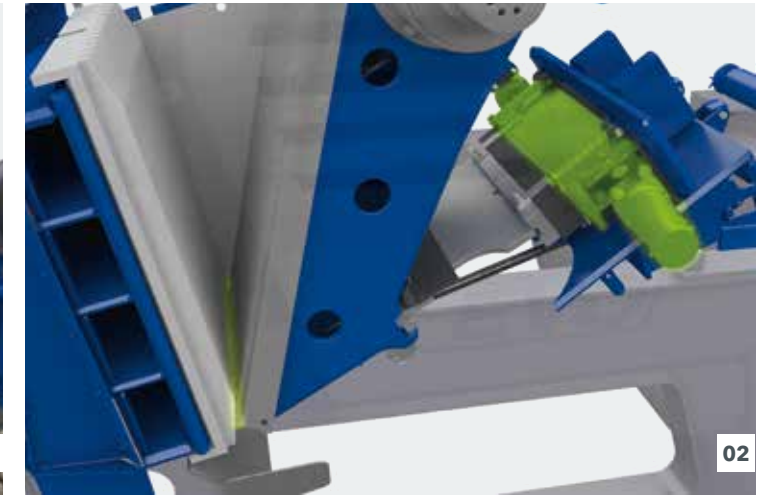

01 Crusher geometry 02 Gap setting 03 Load Reduction System (LRS) 04 Crusher unblocking system

03 Load Reduction System LRS

If crushers are operated beyond their permissible load range, serious damage can be the result. The Load Reduction System LRS will prevent this from taking place.

The "load monitor" in the software detects the overload and intervenes to control it: the loaded volume is reduced, the filling level of the crushing chamber is adjusted and the forces acting on the housing and rocker are thus reduced. If, on the other hand, an underload is detected, the crusher filling level is increased again in steps to guarantee an optimum plant performance.

Result: The plant can also be operated safely with short-term crusher overloading.

04 Crusher unblocking system

If material bridging or a standstill with full crusher should occur, the optional crusher unblocking system provides support. Start-up in normal and opposite directions is also possible with a full crushing chamber. Blockages can thus be quickly broken up and do not have to be cleared manually.

Result: Short downtimes in case of blockages in the crushing chamber.



KLEEMANN > PROCESS KNOWLEDGE

Optimized results through correct loadings:

- > The optimum fill height of the jaw crusher up to the bevelling of the crusher jaws should not be exceeded
- > Continuous overfilling leads to premature wear, reduced service life of bearings and damage to the prescreen
- > Continuous underfilling leads to uneven wear, a poor grain shape and reduced plant performance
- > The maximum feed size of 90% of the feed opening should be observed
- > The CSS should always be correctly set

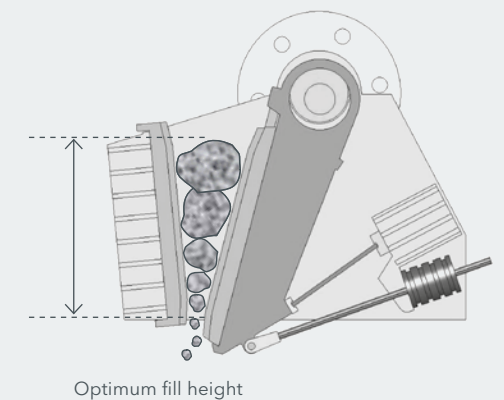

INNOVATIVE DRIVE CONCEPT

Impressive performance - with the best possible consumption values.

The MOBICAT MC 100i EVO features the innovative "diesel-direct" drive concept - it is both powerful and economical.

Equipped with an efficient, powerful diesel engine with fluid coupling, the machine stands out with extremely low efficiency losses: the direct crusher drive provides maximum power directly at the crusher.

All secondary drives - for example, for vibrating chutes and conveyor belts - are driven electrically. The fluid coupling guarantees high operational safety - for both operator and machine.

Diesel-direct Drive | **208 hp** Output | **up to 30% less consumption** compared to hydraulic drives



INTUITIVE CONTROL SYSTEM CONCEPT

For simple operation.

The MC 100i EVO is operated with a simplified and intuitive control system via a touch panel and illuminated push buttons.

Menu-guided operation with a continuous text fault display enables easy, intuitive operation. All components and functions can be controlled conveniently, status displays of the components help during operation.

The touch panel is integrated into a lockable control cabinet that is protected against dust and vibrations. To avoid always having to open the complete control system flap, rapid access to the operator panel is provided via a separate smaller flap (door-in-door). Radio remote control enables ergonomic operation from the excavator.

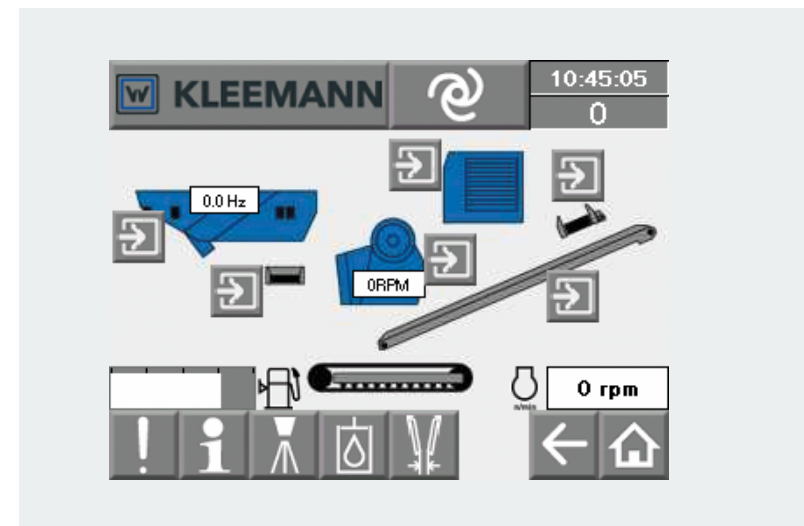

Clearly laid out touch panel with status displays

KLEEMANN > PROCESS KNOWLEDGE

Innovative concept: Economical, safe and resource-preserving.

Diesel-electric drives have advantages over hydraulic drives not only with regard to lower fuel consumption.

The machines also require significantly less hydraulic oil, which has a positive effect on the costs of oil changes and which preserves resources. In the event of leaks, the risk of contamination and environmental pollution is also lower.

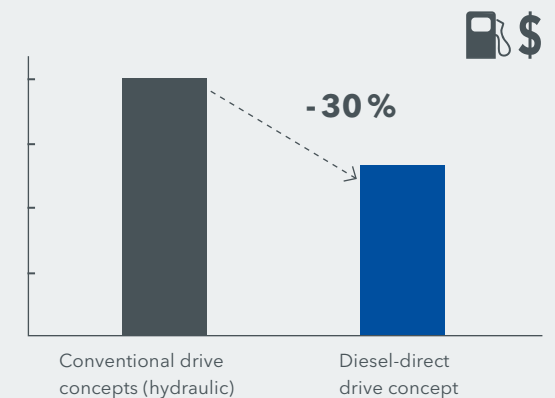

OPTIMIZED CONVEYOR UNIT

With robust crusher discharge conveyor and magnetic separator.



39"-wide
crusher discharge conveyor

Magnetic separator
in two versions

Spray system
for dust reduction



The crushed material is discharged via the wide and robust crusher discharge conveyor, which is available in different lengths. The extended version has a discharge height of 12'. The belt can be folded hydraulically for transport.

The impact table on the crusher discharge conveyor protects the belt. When used for recycling, in particular, puncturing of the belt can be avoided - for a long service life.

To prevent contamination of the final product with ferrous elements, an effective magnetic separator is used. Either an electro-magnet or a permanent magnet can be installed, which can both be raised and lowered by remote control. Material bridging can therefore be broken up very easily and the magnet can always be set to its optimum value. To minimize dust creation, the belt is additionally equipped with a spray system at the belt discharge.

KLEEMANN > PROCESS KNOWLEDGE



Determining the crushing capacity

The machine's crushing capacity can be determined in different ways: apart from the classic method with the help of lorry weigh-bridge, a belt scale integrated into the crushing plant is also available as an option and is installed under the crusher discharge conveyor. This permits quick and simple reading of the crushing capacity via the machine control system.

SIMPLE TRANSPORT

Quickly on site. Immediately ready for work.

In spite of their impressive output values, jaw crushers from the MOBICAT EVO line belong to the compact class of primary crushers: Low weight and compact dimensions enables frequently changing work locations.

The MOBICAT EVO jaw crushers are extremely versatile and, thanks to their compact dimensions, can be deployed almost everywhere directly on site. Even narrow or difficult-to-access building sites in town centres are usually not a problem. And even if the work location changes frequently, the machine can be easily transported and quickly loaded thanks to its relatively light weight.

Upon arrival at the new building site, the machines demonstrate their advantages with their short set-up times: as the feeding unit is integrated into the chassis, folding the hopper walls in and out is not required.

Just as the extended crusher discharge conveyor is simply folded in for transport, the side discharge conveyor also remains on the machine during transport and is moved into position in next to no time. The machine is therefore ready to be started after only a few work steps.



- 10' 6"**
transport height
- 42' 6"**
transport length
- 9' 10"**
transport width
- 66,150 - 78,300 lbs**
transport weight
-  **High flexibility**
for changing work locations
-  **Short make-ready times**
thanks to uncomplicated set-up

FORMULA FOR SUCCESS

For optimal crushing results.

Ideal crushing results are always achieved when components of the entire plant are perfectly tuned to one another, and ideally combined with the settings made by the operator.

With these tips, it is possible to find the ideal settings for any task.

Feed material

- > Feed size: where possible, the maximum feed size should not exceed 90% of the specified crusher opening
- > Compressive strength: mineral materials can be used with a maximum compressive strength of 300 MPa *
- > Mineral type: all soft to hard natural stones, e.g. dolomite, granite, basalt, diabase, quartzite or gneiss as well as residual construction materials such as rubble, bricks and reinforced concrete

* Depending on the material and machine type, higher values are also possible

Crushing ratio

The maximum crushing ratio (ratio of feed grain size / grain output) largely depends on the physical properties of the feed material. The following standard values result:

- > 7:1 at < 100 MPa (recycling)
- > 5:1 at < 150 MPa (limestone)
- > 3-4:1 at < 300 MPa (hard stone)

Exceeding the crushing ratio leads to an undesirable decrease of the crushing capacity and to an increase in wear.



Areas of application of jaw crushing plants

NATURAL STONE

Limestone / sandstone, gritstone / greywacke / gravel / granite	Gneiss / marble / quartzite / diabase / gabbro / basalt	Iron ore	Coal	Clay
Demolished concrete / reinforced concrete / rubble	Asphalt	Blast furnace slag		Steal slag

RECYCLING

KLEEMANN > PROCESS KNOWLEDGE

Crushing curve for the MOBICAT MC 100i EVO

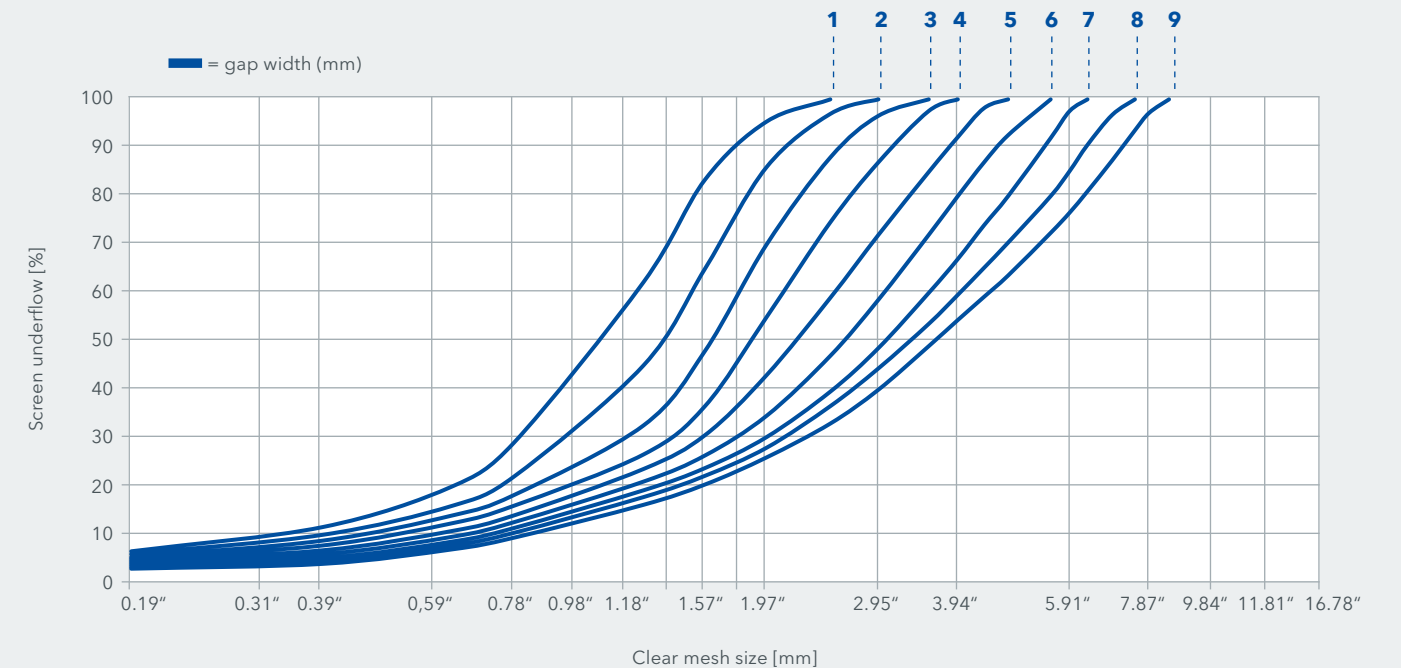

CSS (CLOSED SIDE SETTING)

- 01 1.6" 02 1.97" 03 2.36" 04 2.76" 05 3.15" 06 3.54" 07 3.94" 08 4.33" 09 4.72"

YOUR WIRTGEN GROUP CUSTOMER SUPPORT

Service you can always rely on.

Place your trust in our reliable and fast support during the complete life cycle of your machine. Our wide service offer includes suitable solutions to meet all of your challenges.



Service

We keep our service promises – with fast and simple assistance both on the building site as well as in our professional workshops. Our Service team has received expert training. Thanks to special tools, repair, care and maintenance work is completed quickly. Upon request, we can support you with tailored service agreements.

> www.wirtgen-group.com/service



Spare parts

Original parts and accessories from WIRTGEN GROUP can ensure the high reliability and availability of your machines long term. Our experts will be glad to advise you on application-focused wear part solutions. Our parts are available worldwide, at any time and are easy to order.

> parts.wirtgen-group.com



Training

Staff responsible for the WIRTGEN GROUP's product brands are specialists in their areas and have decades of application experience. Our customers also greatly benefit from these experts. In our WIRTGEN GROUP training courses, we gladly pass on our knowledge to operators and service personnel.

> www.wirtgen-group.com/training



Telematics solutions

Construction machines with leading technology and perfected telematics solutions work hand-in-hand in the WIRTGEN GROUP. The Operations Center* – the platform for digital solutions for process, machine and service optimization – allows you not only to simplify maintenance planning for your machines but also to increase your productivity and cost-effectiveness.

> www.wirtgen-group.com/telematics

* John Deere Operations Center™ (formerly WITOS) is currently not available in all countries. Please consult your responsible branch or dealer if you have any questions in this area.

PROFESSIONAL CRUSHING TOOLS

For less wear and optimum results.

KLEEMANN offers a very wide range of parts and accessories. The selection of the correct crusher jaws, in particular, greatly influences the result: for abrasive rock, for example, different crusher jaws have to be used than for coarse rock.

The crushing principle

The crushing material is crushed by the jaw crushers in the wedge-shaped pit between the fixed crusher jaw and the crusher jaw articulated on an eccentric shaft. The material is crushed by the elliptic course of movement and transported downwards by gravity. This occurs until the material is smaller than the set crushing gap.

In ideal operation, the main wear occurs in the lower half of the crusher jaw. If the teeth are completely worn (smooth crusher jaw), the crusher jaw should be turned over or replaced. The crushing capacity (US t/h) is reduced considerably when the crusher jaws are smooth because the material is mainly crushed and no longer broken. The machine requires more power to break, which results in unnecessarily increased operating costs, higher wear and poorer crushing results.

Low-wear material

The crusher jaws installed in jaw crushers from KLEEMANN are made from a special manganese casting characterised by excellent durability of the basic body. Through the compressive load during operation, the manganese casting forms a highly wear-resistant surface for long service lives.

Timely replacement of worn crusher jaws improves the crushing results and also considerably reduces operating costs.



CRUSHER JAWS

The originals.

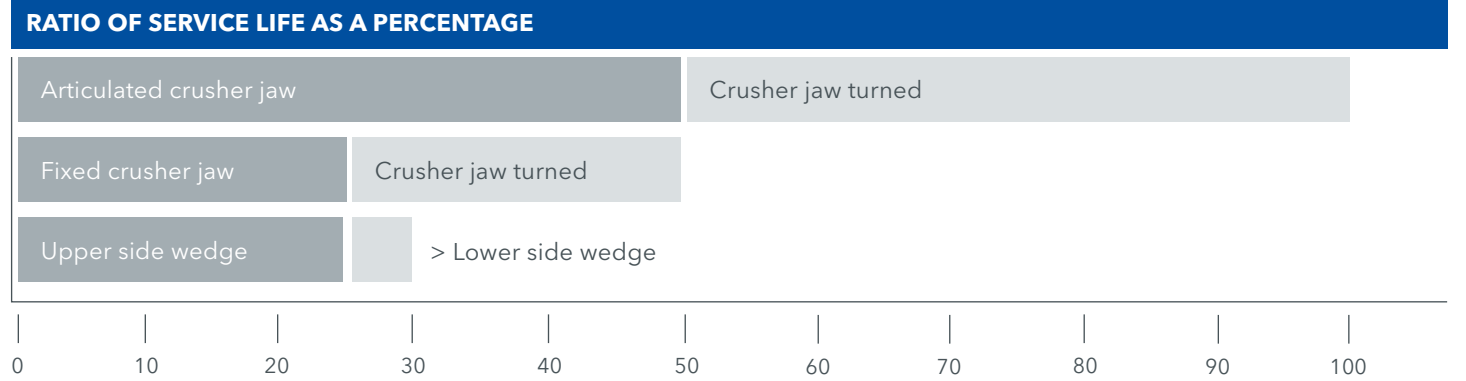

RECOMMENDED USE OF CRUSHER JAWS

Tooth shape	Final product grain size	Feed material				
		Hard stone	Soft and medium-hard rock	Gravel	Rubble/ Recycling	Laminated medium-hard rock
RT* (regular teeth)	> 2.4"	●	●●	●●	●●	●●
ST* (sharp teeth)	< 2.4"	●	●	●●	●	●●

●● Highly recommended ● Recommended ● Not recommended

CRUSHER JAW PROPERTIES

Tooth shape	Illustration	Properties
RT* / ** (regular teeth)		Well-balanced in terms of service life, energy requirements and crushing pressure, suitable for natural stone and recycling.
ST* (sharp teeth)		Sharp teeth reduce the laminated share in the crushed material. Recommended with small gap widths (< 2.4"), suitable for gravel.

* Two quality levels available: > XPERT with 18% manganese
 ** also with chrome inlays, with abrasive natural stone for longer service life



Depending on the application field and material properties, various crusher jaws are available to achieve optimum results.

CRUSHER JAW RT-XPERT / CRUSHER JAW RT-XTRA



- > Ideally balanced properties relating to service life, energy requirements and crushing pressure
- > Ideal tooth spacing for best possible removal of the fines
- > Reduces flaky shares in the crushed material
- > XTRA with higher manganese content for extreme applications



Application options

- > **Natural stone:** slightly to medium abrasive material
- > **Recycling:** rounded material, rubble

CRUSHER JAW ST-EXPERT



- > Good grip on material thanks to sharp tooth profile
- > Reduction of flaky share in crushed material due to sharp tooth profile
- > Recommended with small gap widths (< 2.4")



Application options

- > **Recycling:** rounded material (less abrasive)

TECHNICAL DATA AT A GLANCE

MC 100i EVO



TECHNICAL DATA

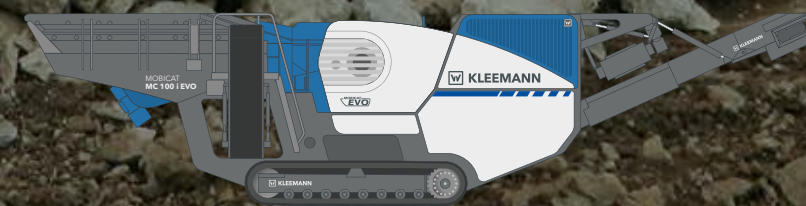

MC 100i EVO

- > Crusher inlet (W X D): 37" x 22"
- > Feed capacity: 243 US t/h
- > Weight: 66,150 - 78,300 lbs



KLEEMANN



WIRTGEN AMERICA

6030 Dana Way
Antioch, TN 37013
USA

T: +1 615 501 0600

M: info.america@wirtgen-group.com

 www.wirtgen-group.com/america