

Technical Information

# MOBICAT MC 110i EVO2



**Track-mounted jaw crusher**  
For use in natural stone and recycling

**MOBICAT EVO2**  
Series

## HIGHLIGHTS

- > Continuous Feed System (CFS) for optimum crusher loading
- > Innovative crusher unblocking system for reduced downtimes
- > Innovative overload and control systems to protect the crusher
- > Independently vibrating double-deck prescreen
- > Efficient and powerful D-DRIVE diesel-direct drive
- > Simple and intuitive SPECTIVE control concept



**MOBICAT MC 110i EVO2 mobile jaw crusher**

The MOBICAT MC 110i EVO2 jaw crusher is used for pre-crushing almost all natural stone and in recycling. This efficient top performer stands out with compact dimensions, efficient

prescreening, simple operation via SPECTIVE, as well as impressive production output.

**MC 110i EVO2 TECHNICAL DATA - US SPEC**

Feeding unit	
Feed capacity up to approx. (US t/h)	441 <sup>1)</sup>
Feed size max.	39" x 25"
Feed height (with extension)	12' 10" (14' 1")
Width x length (with extension)	6' 9" x 11' 1" (9' 1" x 11' 6")
Hopper volume (with extension) (yd <sup>3</sup> )	5.8 (10)
Vibrating feeder	
Width x length	40" x 8' 6"
Prescreening	
Type	Double deck heavy duty screen
Width x length	40" x 6' 1"
Side discharge conveyor <sup>2)</sup>	
Width x length	20" x 8' 10"
Discharge height approx.	6' 9"
Crusher	
Single-toggle jaw crusher model	STR 110 - 070
Crusher inlet width x depth	44" x 28"
Crusher weight approx. (lbs)	37,500
Crusher drive type, approx. (hp)	Direct, 215

Crusher	
Gap width adjustment range	1" - 7" <sup>3)</sup>
Crusher gap adjustment	Fully hydraulic
Crushing capacity <sup>4)</sup>	
Crushing capacity with CSS = 2.4" up to approx. (US t/h)	143
Crushing capacity with CSS = 3.9" up to approx. (t/h)	231
Crusher discharge conveyor	
Width x length	40" x 31' 2"
Discharge height approx.	12' 4"
Power supply unit	
Drive concept	diesel-direct <sup>5)</sup>
Drive output of Scania diesel engine (hp)	326
Generator (kVA)	88
Transport	
Transport height approx.	11' 2"
Transport length approx.	49' 3"
Max. transport width	9' 10"
Transport weight of basic plant - max. configuration approx. (lbs)	102,000 - 106,950

<sup>1)</sup> Depending on the type and composition of the feed material, as well as the feed size, the prescreening and the desired final grain size

<sup>2)</sup> Side discharge conveyor remains attached to the plant for transportation

<sup>3)</sup> CSS: Peak to Valley; the gap width can be adjusted by the use of special crusher jaws

<sup>4)</sup> For hard stone, CSS = Close Side Setting

<sup>5)</sup> Crusher drive, direct, all other main drives are electrical

OPERATING POSITION

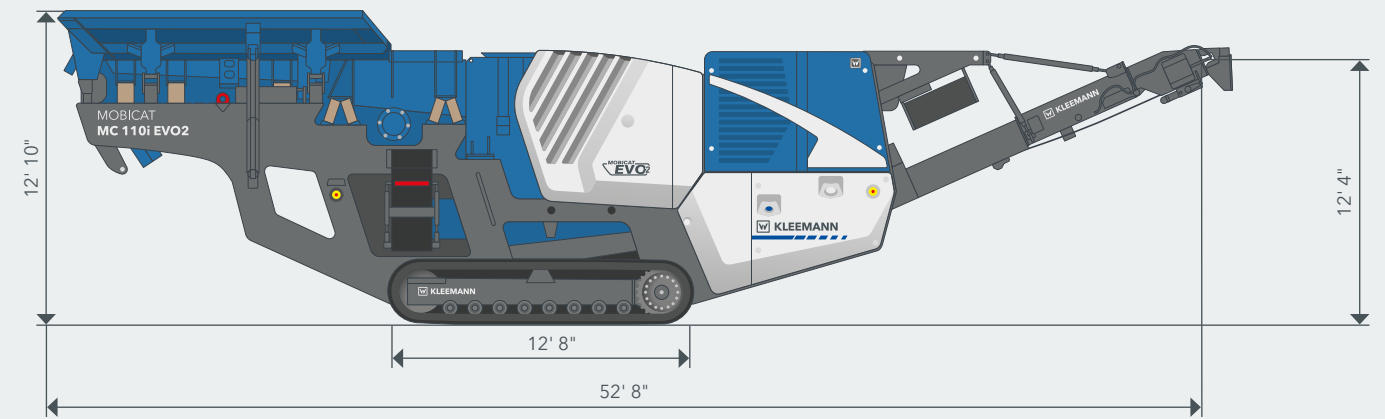

MATERIAL FLOW

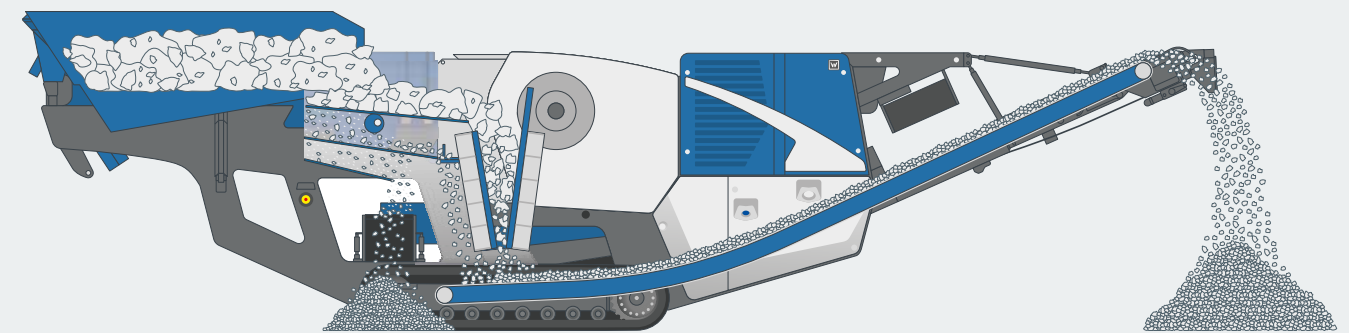

The plant is easy and intuitive to operate, excels with a variety of control and overload systems, and is extremely powerful and efficient in operation. For example, the Continuous Feed System facilitates the work of the operator as the machine automatically regulates a uniform material flow, therefore enabling optimal loading of the crusher. The updated feeder chute design also ensures an

improved material flow. Thanks to its compact dimensions, the MOBICAT MC 110i EVO2 is extremely versatile and quick to transport and load. In addition, thanks to its easy-to-fold components - such as the side discharge conveyor and the extended crusher discharge conveyor - the machine is ready to go in just a few steps.

## STANDARD EQUIPMENT

- > Hydraulically foldable feed hopper
- > Frequency-controlled vibrating feeder, frequency-controlled prescreen. Automatic control as a function of the crusher level thanks to CFS (Continuous Feed System)
- > Extended side discharge conveyor, hydraulic folding, right side, with reinforced conveyor belt, remains on the machine for road transport
- > Intelligent overload system with short-term overloading at selected points for protection of the crusher preparation for active overload system
- > Intelligent load reduction system during long operation under extraordinarily high forces to protect the crusher
- > Prescreen platform in right feed direction next to the chute for maintenance and service activities
- > Jaw crusher with crusher jaws made of high-grade manganese steel
- > Control concept SPECTIVE: menu-prompted user interface, 12 inch operator panel, lockable control cabinet, dust- and vibration-protected; Telematics system for efficient Fleet and Service Management
- > SPECTIVE remote control: Wired and radio remote control incl. switch-off function for feeding unit
- > Extended crusher discharge conveyor, hydraulically foldable; with reinforced conveyor belt
- > Drum scraper crusher discharge conveyor
- > Basic preparation of magnet, with permanent magnetic separator
- > Water spray system for dust reduction
- > Well-thought-out lighting concept for safe plant operation
- > Water pump with pressure monitoring
- > Line coupling for interlinking with other KLEEMANN plants

## OPTIONS

- > SPECTIVE CONNECT for displaying all important machine information directly on the smartphone
- > Hopper extension up to entire hopper volume of approx. 10 yd<sup>3</sup>, rigid design
- > Hopper filling aids for rearward loading: Width of feed opening 11' 6"
- > Short side discharge conveyor, discharge height approx. 6' 9"; remains on the machine for transport
- > Large selection of different prescreen surfaces for lower and upper decks
- > Crusher unblocking system, for starting up the crusher when crushing chamber is full, forward and reverse movement possible
- > Active overload system, very fast reaction to overload, automatic repositioning of the gap
- > Deflector plate (standard) additionally with change elements
- > Diesel refueling pump: Hose system incl. pump, refueling from a separate tank possible
- > Camera system for monitoring the feeding unit and the crusher from the ground, available with additional wireless extension, additional connection to SPECTIVE CONNECT
- > Small radio remote control with the most important operating functions
- > Reinforced conveyor belt for crusher discharge conveyor
- > Crusher discharge conveyor belt cover
- > Belt scale available for crusher discharge conveyor
- > Climate packages: Heat and cold package
- > Increased engine air intake for lower dust load
- > Premium lighting for expanded illumination of work areas
- > Quick Track for selecting machine operating mode quickly and easily, operation via radio remote control
- > Sockets for supplying electrical consumers:  
16 A: 230 V/ 400 V; 32 A: 400 V; 63 A: 400 V
- > Electromagnetic separator

### WIRTGEN AMERICA

6030 Dana Way  
Antioch, TN 37013  
USA

T: +1 615 501 0600  
M: info.america@wirtgen-group.com

[www.wirtgen-group.com/america](http://www.wirtgen-group.com/america)

